

# PAS 128 FIELD MARKING GUIDELINES

## PAS 128 SPECIFICATION UTILITIES CLASSES EXPLAINED – OUR CONCEPT

<b>CLASS</b>	<b>EXPLANATION</b>
<b>A</b>	<b>UTILITY POSITION VALIDATED</b> <b>( 1M EXCLUSION ZONE * )</b>
<b>B</b>	<b>UTILITY ELECTRONITLY TRACED</b> <b>CAT4+/GENNY OR RD8100/TX10</b> <b>( 1M EXCLUSION ZONE * )</b>
<b>C</b>	<b>UTILITY – FEATURE (NON-TRACABLE)</b> <b>( 3M EXCLUSION ZONE * )</b>
<b>D</b>	<b>UTILITY – UNKNOWN POSITION OR</b> <b>ASSUMED POSITION</b> <b>( 3M EXCLUSION ZONE * )</b>

**IF YOU CAN'T SEE IT - DON'T GO NEAR IT!**

\* For exclusion zones for 132kV HV, HPG, HPO refer to the table at the end of this Document.

# **PAS 128 ACCURACY CLASSES EXPLAINED**

## **CLASS A**

Utility visually confirmed / validated through one of the following but not inclusive: trial hole, measurement within a pit, measurement within a gully or foul chamber.

Warning – there is still a very slim chance that what you see in a trench/pothole is not what you think it is – e.g. pipe offcut buried during installation, private connection not available on utility provider records.

As-builts also qualify as Class A.

## **CLASS B**

Utility electronically located with CAT4+ or RD8100 or another locator.

Warning – GPR survey does not qualify as Class B (in our view) and it should be the last resource in providing an accurate location of a utility – e.g. Water Main HDPE.

Each D Class with use of GPR should be verified and brought up to Class A. Only where high confidence is gained through elimination process Class B can be used but only with GPR marking adjacent to it.

## **CLASS C**

Mark adjacent to an existing feature in direction of a utility main line which cannot be traced electronically – e.g. Fire Hydrant on HDPE Water Main, Foul chamber if not surveyed inside.

## **CLASS D**

Line of utility – unknown / assumed position. It should be exposed to prove the alignment.

Exception may be given to Storm Water pipe in roads or several other cases where line can be seen between two gullies or as a scar on a surface. This should be determined by the Underground Services Avoidance Coordinator and documented on Permit to Dig.

D Class may also be used outside the perimeter of permit to dig area to indicatively show other utilities as a guidance. Must be more than 3m away from the permit to dig perimeter.

## **USE OF NUMERIC SYMBOLS**

A simple number from 1 – 50 may represent a depth to the top of utility from the existing surface at the time of locating – e.g. “7B” = 700mm to top of utility based on electronic measurement from RD8100; “4A” = 400 to top of duct adjacent to BT chamber.

## MARKING UTILITIES WITH USE OF PAS 128

These are just a few examples of how to complete marking out the utilities and how to communicate with the crew on the ground:

1. Water Main – C.I. (7 represents 7 \* 100mm to top of utility)

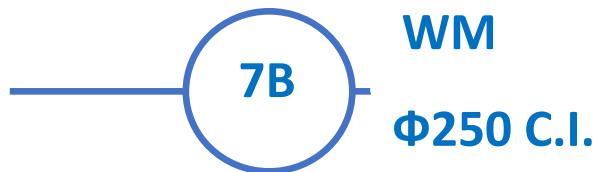

2. Water Main – HDPE

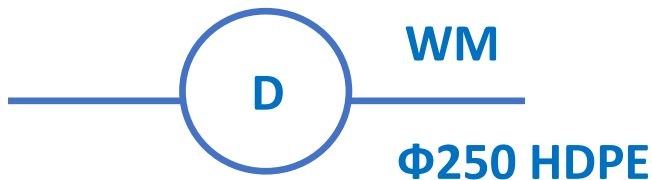

3. Water – domestic connection

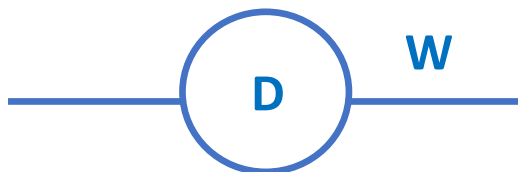

4. Gas Main – e.g. High Pressure Gas Main / Gas Main / HP Oil

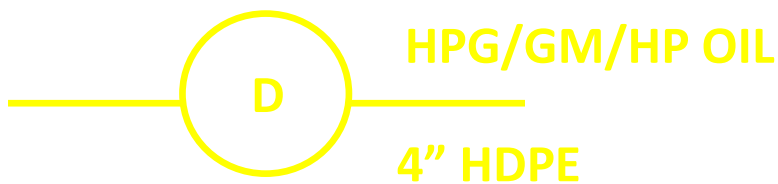

5. Gas - domestic

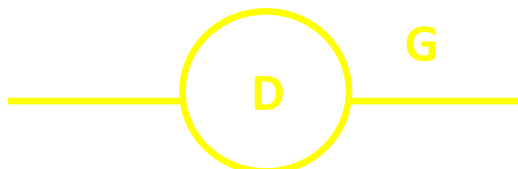

6. Electricity – High Voltage (9 represents 9 \* 100mm to top of utility)

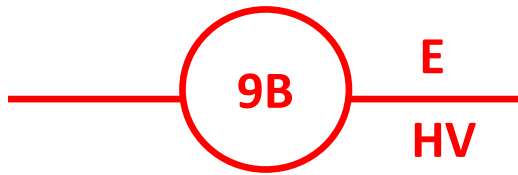

7. Electricity – domestic or LV (6 represents 6 \* 100mm to top of utility)

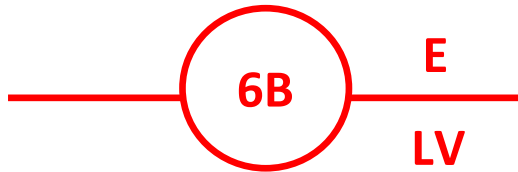

8. Street Lighting / Traffic Lights

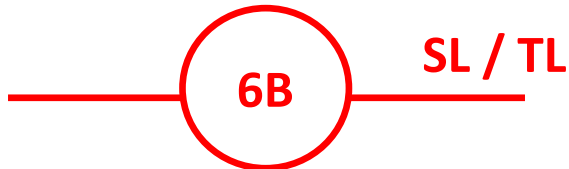

9. Comms (copper) – white paint on the ground (6 represents 6 \* 100mm to top of utility)

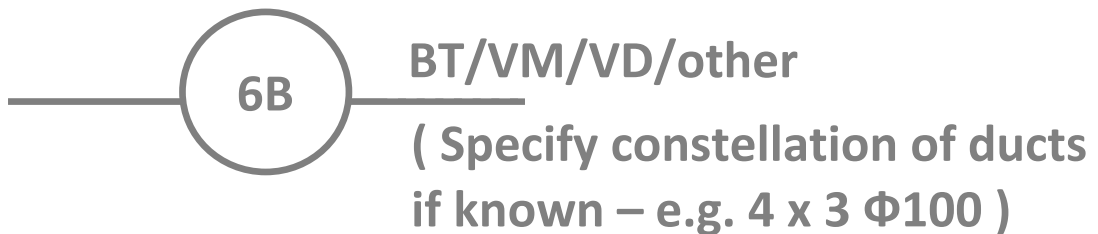

10. Comms (FO) – white paint on the ground – try and use tracing sonde to electronically trace it and bring it up to B Class

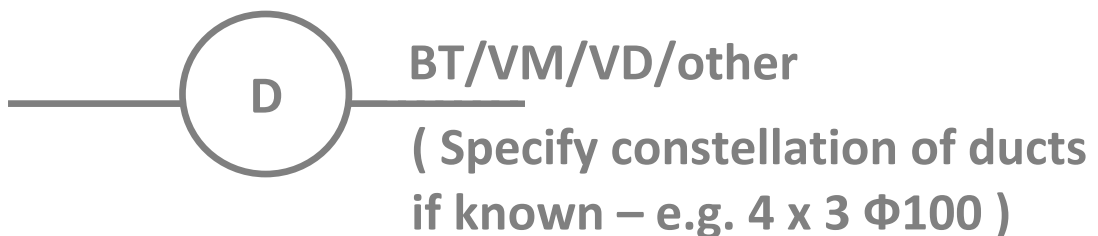

11. Foul Rising Main – light blue or black (the same detail applicable for Gravity Foul)

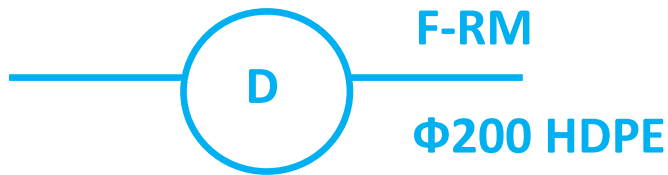

12. Storm Water – light blue or black or green

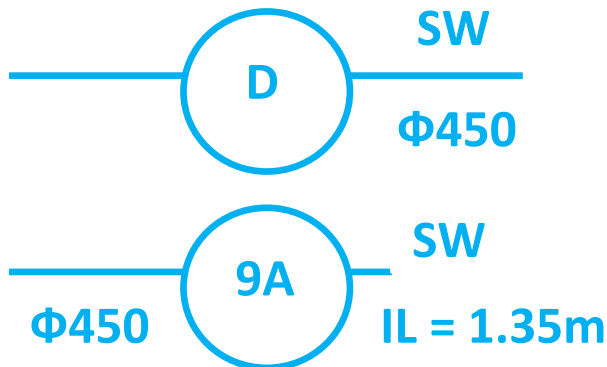

13. Other / Unknown – white paint on the ground (6 represents 6 \* 100mm to top of utility)

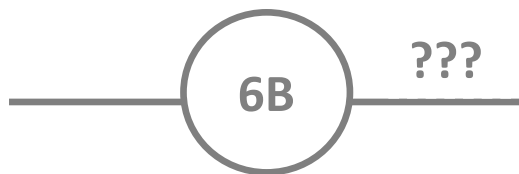

**ONE FINAL ADVICE – EVERYTHING IS SUBJECTIVE.  
IF YOU HAVE ANY DOUBTS ASK.  
REMEMBER – BECAUSE SOMEONE IS “MORE  
EXPERIENCED” IT DOES NOT MEAN HE OR SHE IS  
RIGHT.**

**ALWAYS ANALYSE WHAT YOU DO AND DO NOT BE  
AFRAID TO QUESTION YOURSELF AND OTHERS!  
THIS IS ONE OF THE REASONS WHY WE STRIKE  
SERVICES!**

## MINIMUM EXCLUSION ZONES FOR ANY MECHANICAL EXCAVATION WHEN WORKING AROUND UTILITIES

**FOR PAS 128 CLASS A AND CLASS B**

**FOR INFORMATION ONLY**

Type of Utility	Comment			
	1m	3m	5m	
Not Listed Below				
Water Main / Utility	✓			Contact asset owner to confirm exclusion zone distances for high pressure mains.
Electric HV 11kV	✓			Contact utility owner prior to excavating
Electric HV 25kV	✓			A competent person in attendance is required
Railway up to 33kV	✓			HV Assessment to be undertaken and a competent person in attendance is required.
Electric HV 132kV			✓	Contact utility owner prior to excavating
Electric LV	✓			
Gas ( < 2 bar )	✓			Low and Medium Pressure Mains
Gas ( > 2 bar )		✓		High Pressure ( 7 bar ) – No work must be undertaken without the written consent of the utility owner. Will normally also require attendance by the owner during excavation. Intermediate pressure ( 2 to 7 bar ) – Apply same controls as high pressure unless agreed otherwise in writing with the utility owner.
Telecom	✓			
Fibre Optic	✓			Contact utility owner prior to excavating
CCTV	✓			
Oil Pipelines (CLH)		✓		Contact utility owner prior to excavating